



Modular Piston Coring System.

Description

SYSTEM DESIGN

The piston corer, including the unique launch and recovery system (LARS), has a modular design and is available in four standard lengths of 6 m, 12 m, 18 m and 24 m, but can be customised for your specific project, even to 30 m.

All parts fit in a standard 20-foot container that can be used for transportation, storage and for operations offshore.

All the carbon steel parts are hot-dip galvanised to protect against corrosion.

The system features a standard storage rack, a comprehensive selection of spares, and a complete set of tools for efficient and safe operation.

PISTON CORE OPERATIONS

Piston coring has the advantage over gravity coring because it exerts a reduced downward force on the seabed, minimising the disturbance of the sediments.

The piston corer uses its free-fall kinetic energy and weight to drive the core barrel into the seabed. As the barrel penetrates the seabed, the piston action removes the residual water contained in the sample liner, avoiding any pressure increase above the sample.

This quasi-suction action increases seabed penetration and thereby permits the collection of long, undisturbed sediment samples.

A special valve in the piston allows the operator to select the maximum under-pressure required to prevent the PVC core liner from imploding.

Operational Features

- Modular (all parts fit in a 20-foot container).
- Can be easily configured as required.
- Versatile: 3m, 6 m, 12 m, 18 m, 24 m length.
- Intelligent regulated piston.
- Quality cores of 106 mm diameter.
- Proven sample recovery up to 24 m length.

Deployment Solutions



LARS operations (lifting the piston into the cradle).



Basic 6 m model (without LARS).

Consumables and Accessories

COMPATIBLE CONSUMABLES

All consumables of the Geo-Piston are compatible with our vibrocoring systems: cutting heads, core barrels, liners, caps, core catchers etc. - so we can offer a very competitive price for all our corer consumables.

ACCESSORIES

We can offer a full range of optional accessories:

- hydraulic over-the-side deployment mechanism;
- hydraulic David fo assist the deployment;
- hydraulic core extrusion device;
- longitudinal liner cutter.

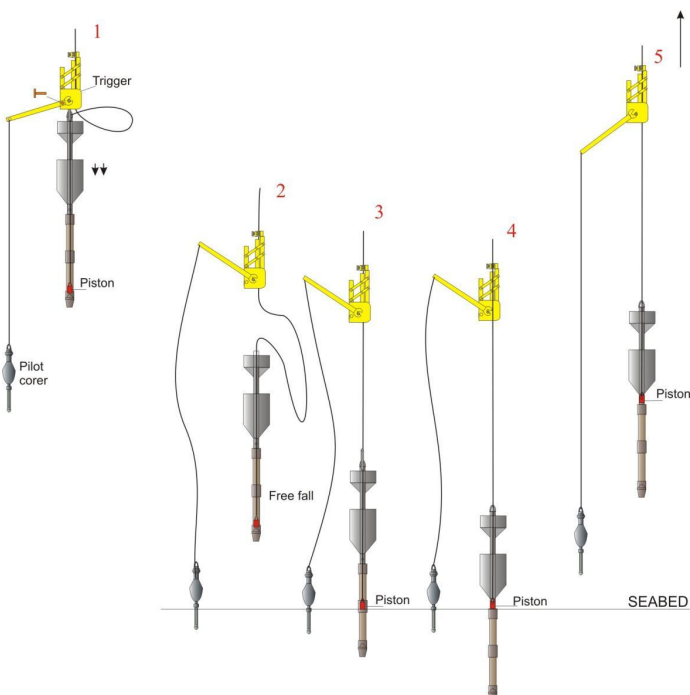

1. Piston corer is deployed in the water and ready for action;
2. Release mechanism is triggered when pilot corer strikes the seabed - piston corer starts its free-fall;
3. Cutting head penetrates sediment and piston removes residual water from above the sediment sample;
4. Core barrel is pushed into the sediment by the core weight as deep as possible (i.e. up to refusal);
5. Piston corer is pulled out and recovered to the surface.

Main Parts

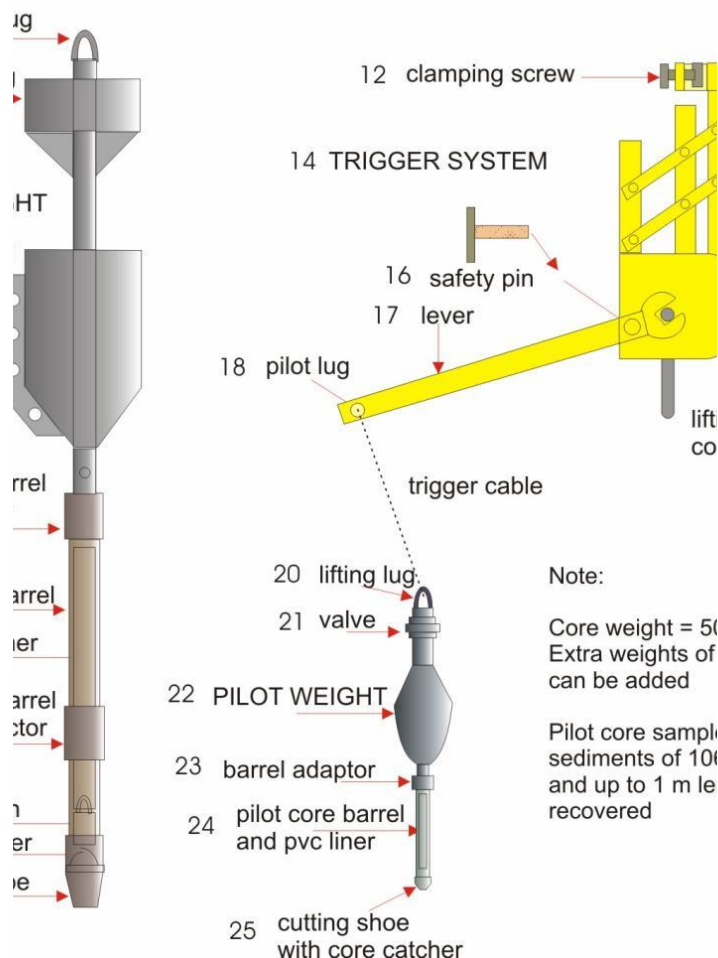

No.	Item	Material
1	lifting lug	stainless steel 316
2	calibrator wing	carbon steel, hot-dip galvanised
3	core weight	lead, carbon steel, hot-dip galvanised
4	hoisting comb	carbon steel, hot-dip galvanised
5	core barrel adaptor	carbon steel, hot-dip galvanised
6	core barrel	stainless steel 316
7	pvc liner	stainless steel 316
8	core barrel connector	shockproof PVC, ID/OD 106 × 110mm
9	piston	stainless steel 316
10	core catcher	Delrin and stainless steel
11	cutting shoe	stainless steel 316
12	clamping screw	carbon steel
13	clamping piece	stainless steel 316
14	trigger system	stainless steel 316
15	shaft bolts	stainless steel 316
16	safety pin	stainless steel 316
17	lever	carbon steel, hot-dip galvanised
18	pilot lug	carbon steel, hot-dip galvanised
19	lifting lug of core weight	carbon steel, hot-dip galvanised
20	lifting lug	stainless steel 316
21	valve	stainless steel 316
22	pilot weight	Delrin
23	pilot core barrel adaptor	lead
24	pilot core barrel	stainless steel 316
25	cutting shoe with core catcher	stainless steel 316

Note:
Core weight = 50kg
Extra weights of 50kg can be added
Pilot core samples of 10cm and up to 1m length can be recovered

Launching Procedure in 7 Steps

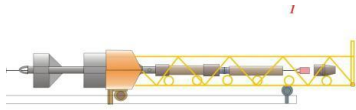

1. Prepare the core tubes and piston.

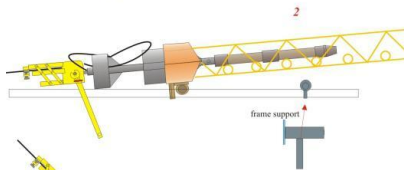

2. Lift the launch system over the side.

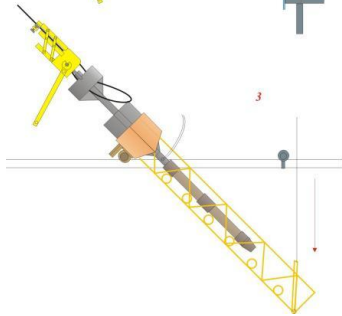

3. Lower the launch system using davit/crane.

4. Set the piston corer in vertical position.

5. Attach the pilot corer then lift the whole assembly to transfer from davit/crane to the oceanographic winch

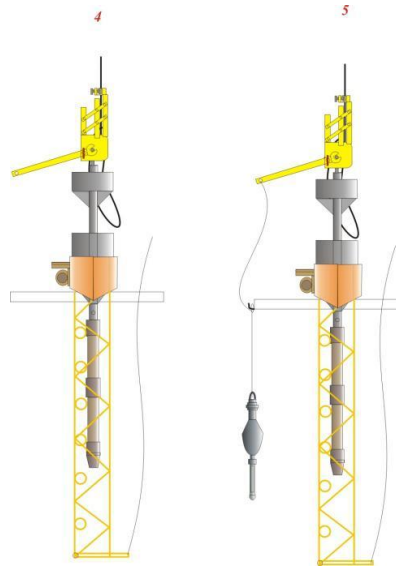

6. Attach the piston corer to the oceanographic winch and prepare to power

7. Remove the safety pin then lower the piston corer to the seabed

